

CREATE YOUR OWN SPEAKER DOCK WITH THIS

# 3W STEREO AMPLIFIER KIT

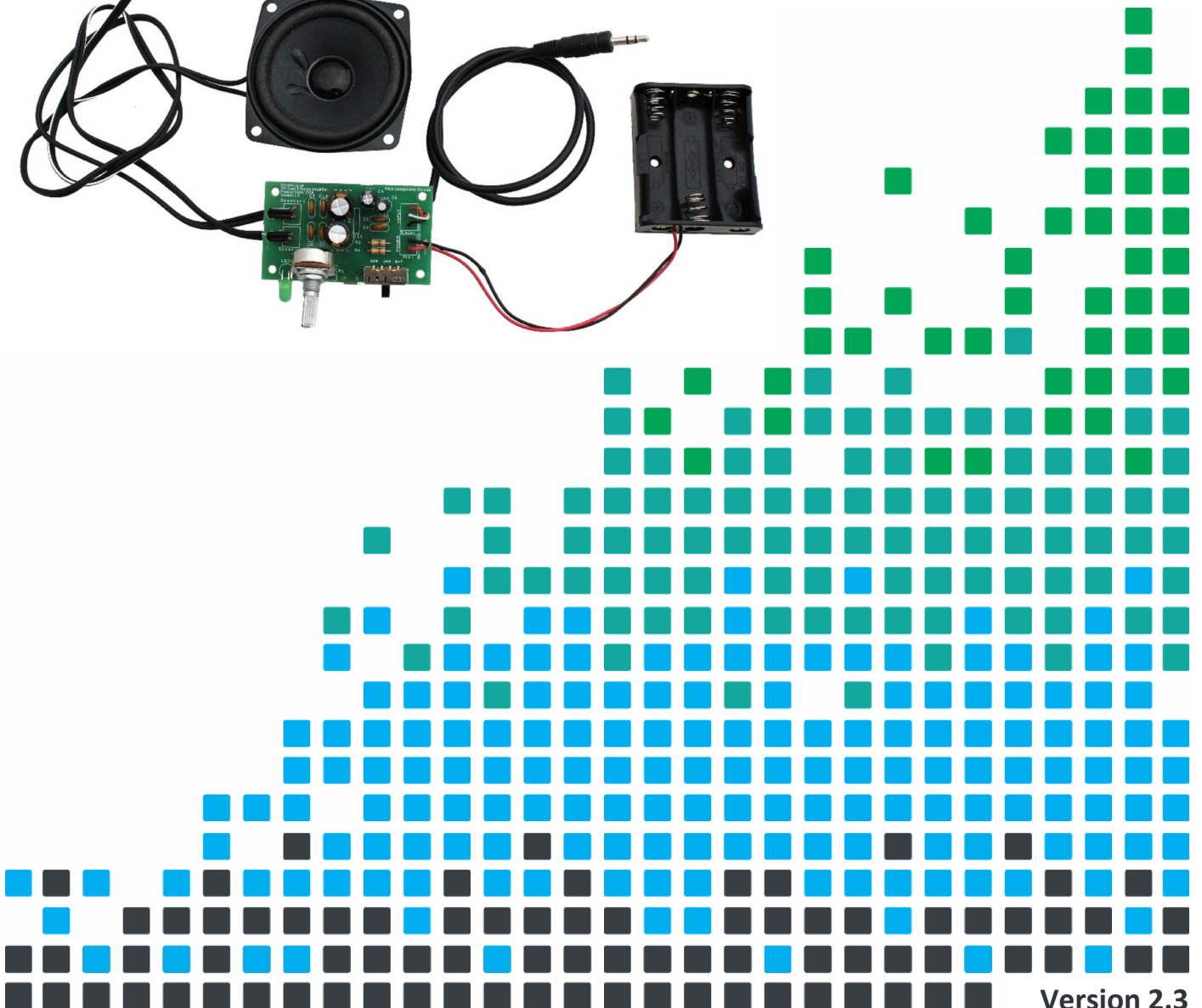
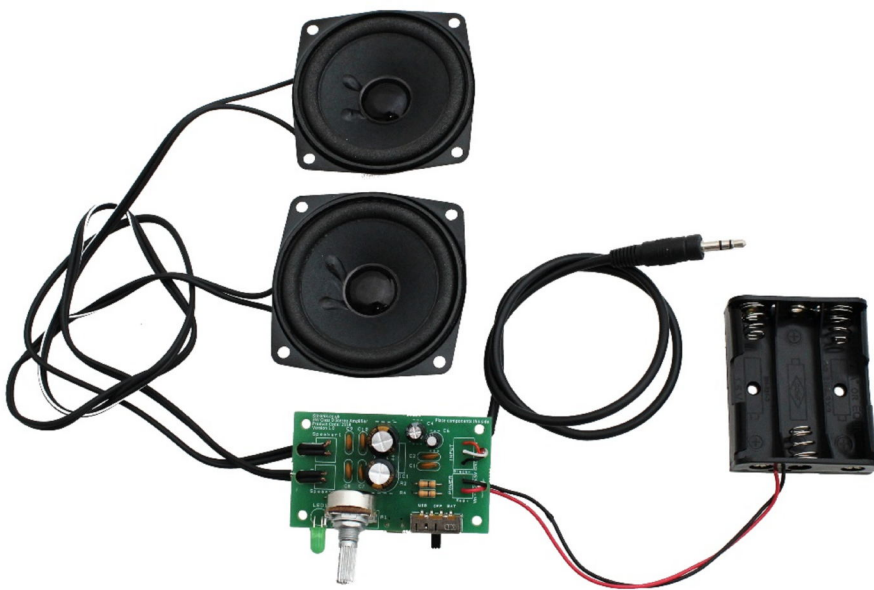

## Index of Sheets

### TEACHING RESOURCES

- Index of Sheets
- Introduction
- Schemes of Work
- Answers
- The Design Process
- The Design Brief
- Investigation / Research
- Developing a Specification
- Design
- Design Review (group task)
- Soldering in Ten Steps
- Resistor Values
- LEDs & Current Limit Resistors
- Capacitor Basics
- Ceramic Disc Capacitors
- Instruction Manual
- Evaluation
- Packaging Design

### ESSENTIAL INFORMATION

- Build Instructions
- Checking Your Amplifier PCB
- Fault Finding
- Designing the Enclosure
- How the Amplifier Works
- Online Information



## Introduction

### ***About the project kit***

Both the project kit and the supporting material have been carefully designed for use in KS3 Design and Technology lessons. The project kit has been designed so that even teachers with a limited knowledge of electronics should have no trouble using it as a basis from which they can form a scheme of work.

The project kits can be used in two ways:

1. As part of a larger project involving all aspects of a product design, such as designing an enclosure for the electronics to fit into.
2. On their own as a way of introducing electronics and electronic construction to students over a number of lessons.

This booklet contains a wealth of material to aid the teacher in either case.

### ***Using the booklet***

The first few pages of this booklet contains information to aid the teacher in planning their lessons and also covers worksheet answers. The rest of the booklet is designed to be printed out as classroom handouts. In most cases all of the sheets will not be needed, hence there being no page numbers, teachers can pick and choose as they see fit.

Please feel free to print any pages of this booklet to use as student handouts in conjunction with Kitronik project kits.

### ***Support and resources***

You can also find additional resources at [www.kitronik.co.uk](http://www.kitronik.co.uk). There are component fact sheets, information on calculating resistor and capacitor values, puzzles and much more.

Kitronik provide a next day response technical assistance service via e-mail. If you have any questions regarding this kit or even suggestions for improvements, please e-mail us at:

support@kitronik.co.uk

Alternatively, phone us on 0845 8380781.



## Schemes of Work

Two schemes of work are included in this pack; the first is a complete project including the design & manufacture of an enclosure for the kit (below). The second is a much shorter focused practical task covering just the assembly of the kit (next page). Equally, feel free to use the material as you see fit to develop your own schemes.

Before starting we would advise that you to build a kit yourself. This will allow you to become familiar with the project and will provide a unit to demonstrate.

### **Complete product design project including electronics and enclosure**

Hour 1	Introduce the task using 'The Design Brief' sheet. Demonstrate a built unit. Take students through the design process using 'The Design Process' sheet. <u>Homework</u> : Collect examples of MP3 players & accessories. List the common features of these products on the 'Investigation / Research' sheet.
Hour 2	Develop a specification for the project using the 'Developing a Specification' sheet. <u>Resource</u> : Sample of products (amplifiers & MP3 player accessories). <u>Homework</u> : Using the internet or other search method, find out what is meant by 'design for manufacture'. List five reasons why design for manufacture should be considered on any design project.
Hour 3	Read 'Designing the Enclosure' sheet. Develop a product design using the 'Design' sheet. <u>Homework</u> : Complete design.
Hour 4	Using cardboard, get the students to model their enclosure design. Allow them to make alterations to their design if the model shows any areas that need changing.
Hour 5	Split the students into groups and get them to perform a group design review using the 'Design Review' sheet.
Hour 6	Using the 'Soldering in Ten Steps' sheet, demonstrate and get students to practice soldering. Start the 'Resistor Values' and 'Ceramic Disc Capacitors' worksheets. <u>Homework</u> : Complete any of the remaining resistor / capacitor tasks.
Hour 7	Build the electronic kit using the 'Build Instructions'.
Hour 8	Complete the build of the electronic kit. Check the completed PCB and fault find if required using the 'Checking Your Amplifier PCB' section and the fault finding flow chart. <u>Homework</u> : Read 'How the Amplifier Works' sheet.
Hour 9	Build the enclosure. <u>Homework</u> : Collect some examples of instruction manuals.
Hour 10	Build the enclosure. <u>Homework</u> : Read 'Instruction Manual' sheet and start developing instructions for the amplifier.
Hour 11	Build the enclosure.
Hour 12	Using the 'Evaluation' sheet, get the students to evaluate their final product and state where improvements can be made.

### **Additional Work**

Package design for those who complete ahead of others.



# 3W Stereo Amplifier Teaching Resources



www.kitronik.co.uk/2158

## Electronics only

Hour 1	Introduction to the kit demonstrating a built unit. Using the 'Soldering in Ten Steps' sheet, practice soldering.
Hour 2	Build the kit using the 'Build Instructions'.
Hour 3	Check the completed PCB and fault find if required using 'Checking Your Amplifier PCB' and fault finding flow chart.

## Answers

### Resistor questions

1st Band	2nd Band	Multiplier x	Value
Brown	Black	Yellow	100,000 $\Omega$
Green	Blue	Brown	560 $\Omega$
Brown	Grey	Yellow	180,000 $\Omega$
Orange	White	Black	39 $\Omega$

Value	1st Band	2nd Band	Multiplier x
180 $\Omega$	Brown	Grey	Brown
3,900 $\Omega$	Orange	White	Red
47,000 (47K) $\Omega$	Yellow	Violet	Orange
1,000,000 (1M) $\Omega$	Brown	Black	Green

### Capacitor Ceramic Disc values

Printing on capacitor	Two digit start	Number of zero's	Value in pF
222	22	00	2200pF (2.2nF)
103	10	000	10000pF (10nF)
333	33	000	33000pF (33nF)
473	47	000	47000pF (47nF)



## The Design Process

The design process can be short or long, but will always consist of a number of steps that are the same on every project. By splitting a project into these clearly defined steps, it becomes more structured and manageable. The steps allow clear focus on a specific task before moving to the next phase of the project. A typical design process is shown on the right.

### **Design brief**

What is the purpose or aim of the project? Why is it required and who is it for?

### **Investigation**

Research the background of the project. What might the requirements be? Are there competitors and what are they doing? The more information found out about the problem at this stage, the better, as it may make a big difference later in the project.

### **Specification**

This is a complete list of all the requirements that the project must fulfil - no matter how small. This will allow you to focus on specifics at the design stage and to evaluate your design. Missing a key point from a specification can result in a product that does not fulfil its required task.

### **Design**

Develop your ideas and produce a design that meets the requirements listed in the specification. At this stage it is often normal to prototype some of your ideas to see which work and which do not.

### **Build**

Build your design based upon the design that you have developed.

### **Evaluate**

Does the product meet all points listed in the specification? If not, return to the design stage and make the required changes. Does it then meet all of the requirements of the design brief? If not, return to the specification stage and make improvements to the specification that will allow the product to meet these requirements and repeat from this point. It is normal to have such iterations in design projects, though you normally aim to keep these to a minimum.

### **Improve**

Do you feel the product could be improved in any way? These improvements can be added to the design.

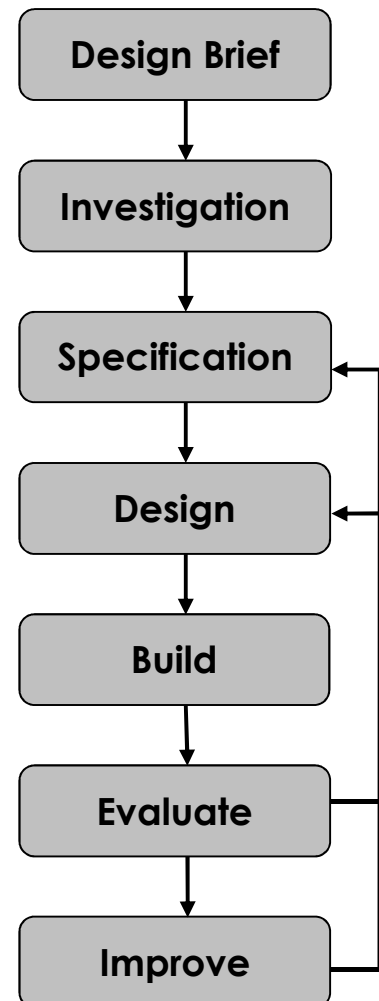

## The Design Brief

A manufacturer of MP3 players has developed an audio amplifier circuit. The circuit has been developed to the point where they have a working Printed Circuit Board (PCB). Although they are used to the design of MP3 players, they have not designed an amplifier case before.

The manufacturer would like ideas for an enclosure for the PCB, batteries and speakers to be mounted in. The manufacturer has asked you to do this for them. It is important that you make sure the final design meets all of the requirements that you identify for such a product.



## Complete Circuit

A fully built circuit is shown below.

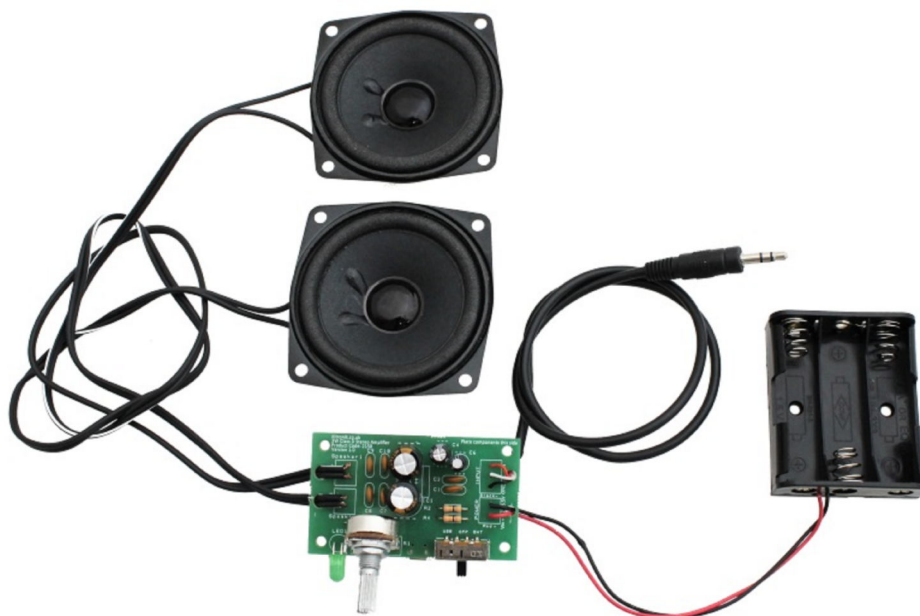

## Investigation / Research

Using a number of different search methods, find examples of similar products that are already on the market. Use additional pages if required.

Name.....

Class.....





## Developing a Specification

Using your research into the target market for the product, identify the key requirements for the product and explain why each of these is important.

Name.....

Class.....

Requirement	Reason
Example: The enclosure should have some holes.	Example: So that the sound can be heard.



## Design

Develop your ideas to produce a design that meets the requirements listed in the specification.

Name.....

Class.....



## Design Review (group task)

Split into groups of three or four. Take it in turns to review each person's design against the requirements of their specification. Also look to see if you can spot any additional aspects of each design that may cause problems with the final product. This will allow you to ensure that you have a good design and catch any faults early in the design process. Note each point that is made and the reason behind it. Decide if you are going to accept or reject the comment made. Use these points to make improvements to your initial design.

Comment	Reason for comment	Accept or Reject



## Soldering in Ten Steps

1. Start with the smallest components working up to the taller components, soldering any interconnecting wires last.
2. Place the component into the board, making sure that it goes in the right way around and the part sits flush against the board.
3. Bend the leads slightly to secure the part.
4. Make sure that the soldering iron has warmed up and if necessary, use the damp sponge to clean the tip.
5. Place the soldering iron on the pad.
6. Using your free hand, feed the end of the solder onto the pad (top picture).
7. Remove the solder, then the soldering iron.
8. Leave the joint to cool for a few seconds.
9. Using a pair of cutters, trim the excess component lead (middle picture).
10. If you make a mistake heat up the joint with the soldering iron, whilst the solder is molten, place the tip of your solder extractor by the solder and push the button (bottom picture).

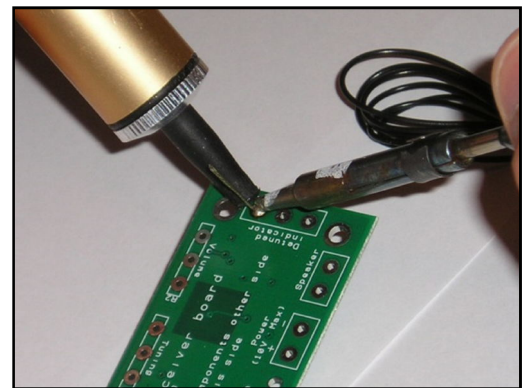
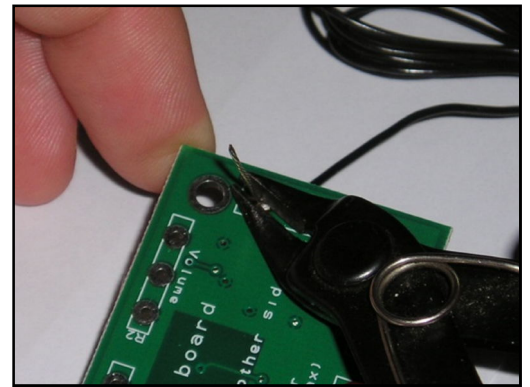
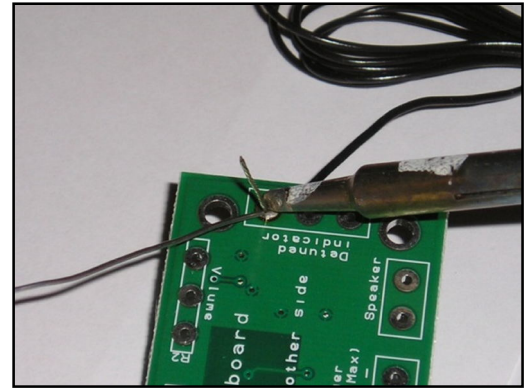

## Solder joints

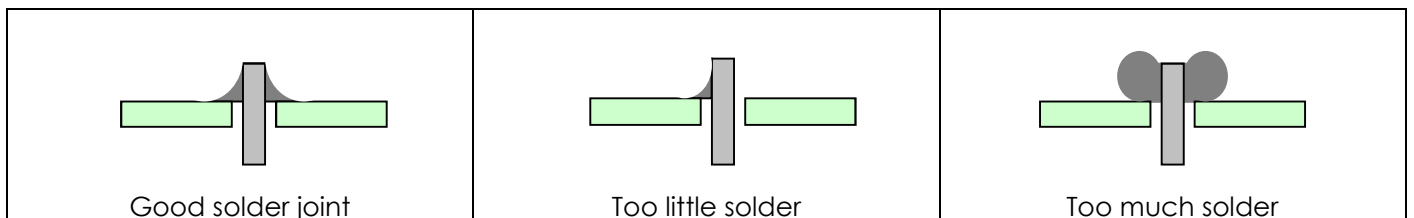

## Resistor Values

A resistor is a device that opposes the flow of electrical current. The bigger the value of a resistor, the more it opposes the current flow. The value of a resistor is given in  $\Omega$  (ohms) and is often referred to as its 'resistance'.

### Identifying resistor values

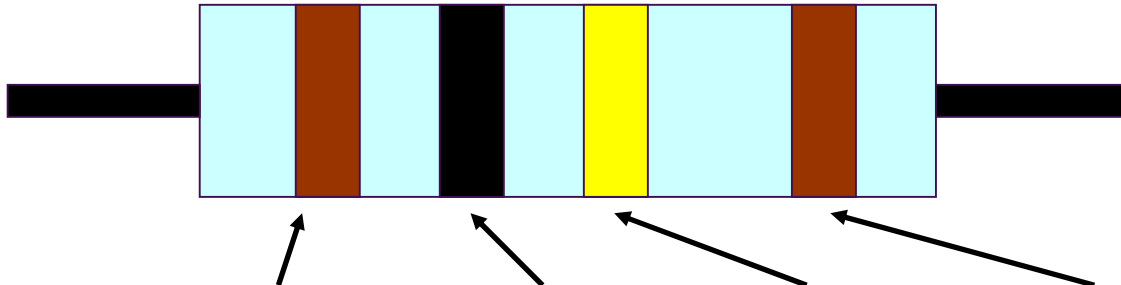

Band Colour	1st Band	2nd Band	Multiplier x	Tolerance
Silver			$\div 100$	10%
Gold			$\div 10$	5%
Black	0	0	1	
Brown	1	1	10	1%
Red	2	2	100	2%
Orange	3	3	1000	
Yellow	4	4	10,000	
Green	5	5	100,000	
Blue	6	6	1,000,000	
Violet	7	7		
Grey	8	8		
White	9	9		

Example: Band 1 = Red, Band 2 = Violet, Band 3 = Orange, Band 4 = Gold

The value of this resistor would be:

$$\begin{aligned}
 & \mathbf{2} \text{ (Red)} \mathbf{7} \text{ (Violet)} \times \mathbf{1,000} \text{ (Orange)} & = 27 \times 1,000 \\
 & & = \mathbf{27,000} \text{ with a 5\% tolerance (gold)} \\
 & & = \mathbf{27K\Omega}
 \end{aligned}$$

#### Too many zeros?

Kilo ohms and mega ohms can be used:

$$1,000\Omega = 1K$$

$$1,000K = 1M$$

### Resistor identification task

Calculate the resistor values given by the bands shown below. The tolerance band has been ignored.

1st Band	2nd Band	Multiplier x	Value
Brown	Black	Yellow	
Green	Blue	Brown	
Brown	Grey	Yellow	
Orange	White	Black	



## Calculating resistor markings

Calculate what the colour bands would be for the following resistor values.

Value	1st Band	2nd Band	Multiplier x
180 $\Omega$			
3,900 $\Omega$			
47,000 (47K) $\Omega$			
1,000,000 (1M) $\Omega$			

## What does tolerance mean?

Resistors always have a tolerance but what does this mean? It refers to the accuracy to which it has been manufactured. For example if you were to measure the resistance of a gold tolerance resistor you can guarantee that the value measured will be within 5% of its stated value. Tolerances are important if the accuracy of a resistors value is critical to a design's performance.

## Preferred values

There are a number of different ranges of values for resistors. Two of the most popular are the E12 and E24. They take into account the manufacturing tolerance and are chosen such that there is a minimum overlap between the upper possible value of the first value in the series and the lowest possible value of the next. Hence there are fewer values in the 10% tolerance range.

E-12 resistance tolerance ( $\pm 10\%$ )											
10	12	15	18	22	27	33	39	47	56	68	82

E-24 resistance tolerance ( $\pm 5\%$ )											
10	11	12	13	15	16	18	20	22	24	27	30
33	36	39	43	47	51	56	62	68	75	82	91



## LEDs & Current Limit Resistors

Before we look at LEDs, we first need to start with diodes. Diodes are used to control the direction of flow of electricity. In one direction they allow the current to flow through the diode, in the other direction the current is blocked.

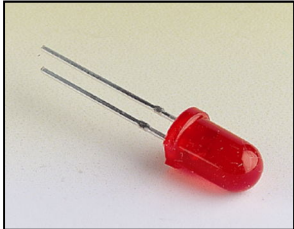

An LED is a special diode. LED stands for Light Emitting Diode. LEDs are like normal diodes, in that they only allow current to flow in one direction, however when the current is flowing the LED lights. The symbol for an LED is the same as the diode but with the addition of two arrows to show that there is light coming from the diode. As the LED only allows current to flow in one direction, it's important that we can work out which way the electricity will flow. This is indicated by a flat edge on the LED.

For an LED to light properly, the amount of current that flows through it needs to be controlled. To do this we use a current limit resistor. If we didn't use a current limit resistor the LED would be very bright for a short amount of time, before being permanently destroyed.

To work out the best resistor value we need to use Ohms Law. This connects the voltage across a device and the current flowing through it to its resistance.

Ohms Law tells us that the flow of current ( $I$ ) in a circuit is given by the voltage ( $V$ ) across the circuit divided by the resistance ( $R$ ) of the circuit.

$$I = \frac{V}{R}$$

Like diodes, LEDs drop some voltage across them. For a high brightness white LED this is 3.5 volts.

Suppose this LED is run off a 5V supply there must be a total of 5 volts dropped across the LED ( $V_{LED}$ ) and the resistor ( $V_R$ ). As the LED manufacturer's datasheet tells us that there is 3.5 volts dropped across the LED, there must be 1.5 volts dropped across the resistor. ( $V_{LED} + V_R = 3.5 + 1.5 = 5V$ ).

LEDs normally need about 10mA to operate at a good brightness. Since we know that the voltage across the current limit resistor is 1.5 volts and we know that the current flowing through it is 0.01 Amps, the resistor can be calculated.

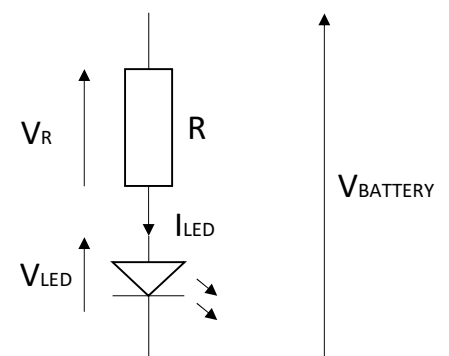

Using Ohms Law in a slightly rearranged format:

$$R = \frac{V}{I} = \frac{1.5}{0.01} = 150\Omega$$

Hence in this circuit we would need a 150 $\Omega$  current limit resistor.



## LEDs Continued

### Packages

LEDs are available in many shapes and sizes. The 5mm round LED is the most common. The colour of the plastic lens is often the same as the actual colour of light emitted – but not always with high brightness LEDs.

### Advantages of using LEDs over bulbs

Some of the advantages of using an LED over a traditional bulb are:

Power efficiency	LEDs use less power to produce the same amount of light, which means that they are more efficient. This makes them ideal for battery power applications.
Long life	LEDs have a very long life when compared to normal light bulbs. They also fail by gradually dimming over time instead of a sharp burn out.
Low temperature	Due to the higher efficiency of LEDs, they can run much cooler than a bulb.
Hard to break	LEDs are much more resistant to mechanical shock, making them more difficult to break than a bulb.
Small	LEDs can be made very small. This allows them to be used in many applications, which would not be possible with a bulb.
Fast turn on	LEDs can light up faster than normal light bulbs, making them ideal for use in car break lights.

### Disadvantages of using LEDs

Some of the disadvantages of using an LED over a traditional bulb are:

Cost	LEDs currently cost more for the same light output than traditional bulbs. However, this needs to be balanced against the lower running cost of LEDs due to their greater efficiency.
Drive circuit	To work in the desired manner, an LED must be supplied with the correct current. This could take the form of a series resistor or a regulated power supply.
Directional	LEDs normally produce a light that is focused in one direction, which is not ideal for some applications.

### Typical LED applications

Some applications that use LEDs are:

- Bicycle lights
- Car lights (break and headlights)
- Traffic lights
- Indicator lights on consumer electronics
- Torches
- Backlights on flat screen TVs and displays
- Road signs
- Information displays
- Household lights
- Clocks





## Capacitor Basics

### What is a capacitor?

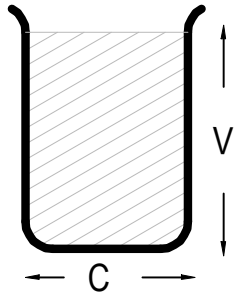

A capacitor is a component that can store electrical charge (electricity). In many ways, it is like a rechargeable battery.

A good way to imagine a capacitor is as a bucket, where the size of the base of the bucket is equivalent to the capacitance ( $C$ ) of the capacitor and the height of the bucket is equal to its voltage rating ( $V$ ).

The amount that the bucket can hold is equal to the size of its base multiplied by its height, as shown by the shaded area.

### Filling a capacitor with charge

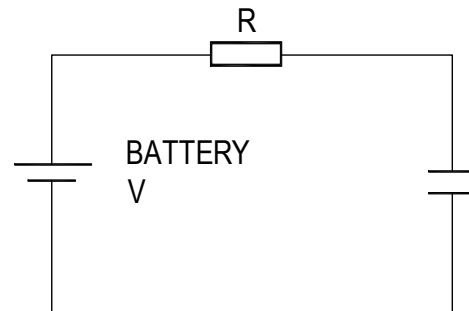
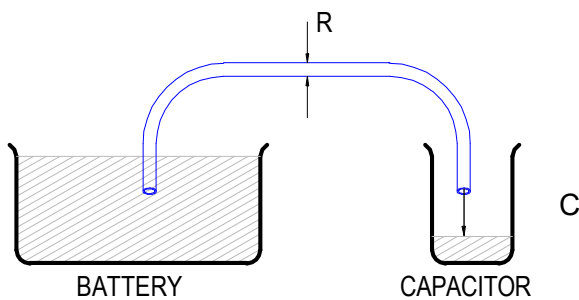

When a capacitor is connected to an item such as a battery, charge will flow from the battery into it. Therefore the capacitor will begin to fill up. The flow of water in the picture above left is the equivalent of how the electrical charge will flow in the circuit shown on the right.

The speed at which any given capacitor will fill depends on the resistance ( $R$ ) through which the charge will have to flow to get to the capacitor. You can imagine this resistance as the size of the pipe through which the charge has to flow. The larger the resistance, the smaller the pipe and the longer it will take for the capacitor to fill.

### Emptying (discharging) a capacitor

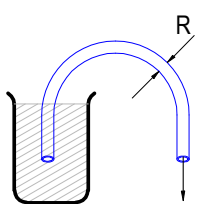

Once a capacitor has been filled with an amount of charge, it will retain this charge until it is connected to something into which this charge can flow.

The speed at which any given capacitor will lose its charge will, like when charging, depend on the resistance ( $R$ ) of the item to which it is connected. The larger the resistance, the smaller the pipe and the longer it will take for the capacitor to empty.

### Maximum working voltage

Capacitors also have a maximum working voltage that should not be exceeded. This will be printed on the capacitor or can be found in the catalogue the part came from. You can see that the capacitor on the right is printed with a 10V maximum working voltage.

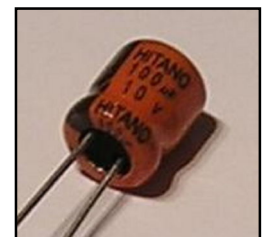

## Ceramic Disc Capacitors

### Values

The value of a capacitor is measured in Farads, though a 1 Farad capacitor would be very big. Therefore we tend to use milli Farads (mF), micro Farads ( $\mu\text{F}$ ), nano Farads (nF) and pico Farads (pF). A  $\mu\text{F}$  is a millionth of a Farad,  $1\mu\text{F} = 1000\text{ nF}$  and  $1\text{nF} = 1000\text{ pF}$ .

1F	= 1,000mF
1F	= 1,000,000 $\mu\text{F}$
1F	= 1,000,000,000nF
1F	= 1,000,000,000,000pF

The larger electrolytic capacitors tend to have the value printed on the side of them along with a black band showing the negative lead of the capacitor.

Other capacitors, such as the ceramic disc capacitor shown on the right, use a code. They are often smaller and may not have enough space to print the value in full, hence the use of the 3-digit code. The first 2 digits are the first part of the number and the third digit gives the number of zeros to give its value in pF.



Example:  $104 = 10 + 0000$  (4 zero's) = **100,000 pF** (which is also  $0.1\ \mu\text{F}$ )

Work out what value the four capacitors are in the table below.

Printing on capacitor	Two digit start	Number of zero's	Value in pF
222			
103			
333			
473			



## Instruction Manual

Your amplifier is going to be supplied with some instructions. Identify four points that must be included in the instructions and give a reason why.

Point to include:

Reason:

Point to include:

Reason:

Point to include:

Reason:

Point to include:

Reason:



## Evaluation

It is always important to evaluate your design once it is complete. This will ensure that it has met all of the requirements defined in the specification. In turn, this should ensure that the design fulfils the design brief.

Check that your design meets all of the points listed in your specification.

Show your product to another person (in real life this person should be the kind of person at which the product is aimed). Get them to identify aspects of the design, which parts they like and aspects that they feel could be improved.

Good aspects of the design	Areas that could be improved

## Improvements

Every product on the market is constantly subject to redesign and improvement. What aspects of your design do you feel you could improve? List the aspects that could be improved and where possible, draw a sketch showing the changes that you would make.



## Packaging Design

If your product was to be sold in a high street electrical retailer, what requirements would the packaging have? List these giving the reason for the requirement.

Requirement	Reason

Develop a packaging design for your product that meets these requirements. Use additional pages if required.





## ESSENTIAL INFORMATION

BUILD INSTRUCTIONS  
CHECKING YOUR PCB & FAULT-FINDING  
MECHANICAL DETAILS  
HOW THE KIT WORKS

CREATE YOUR OWN SPEAKER DOCK WITH THIS

# 3W STERERO AMPLIFIER KIT

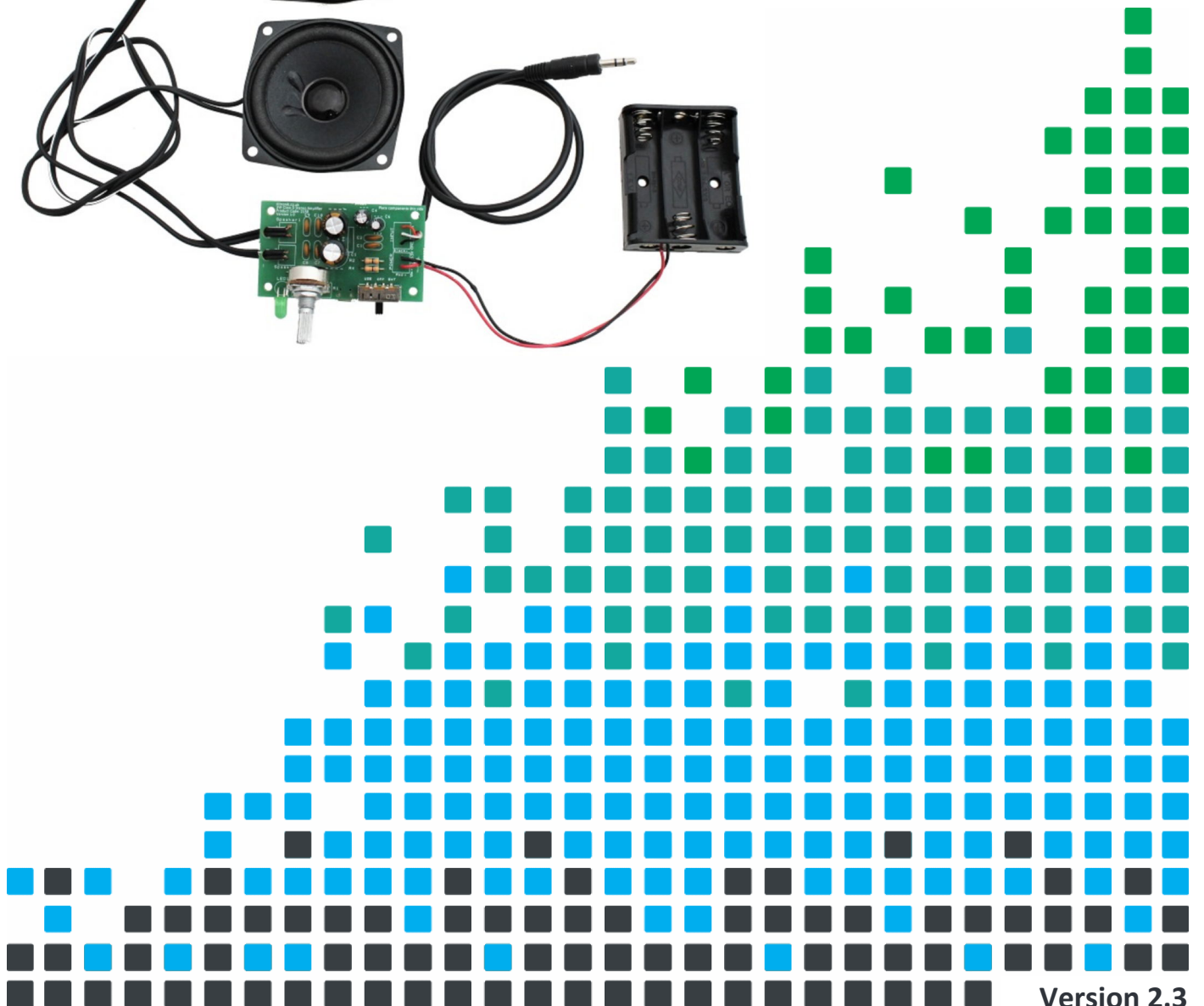
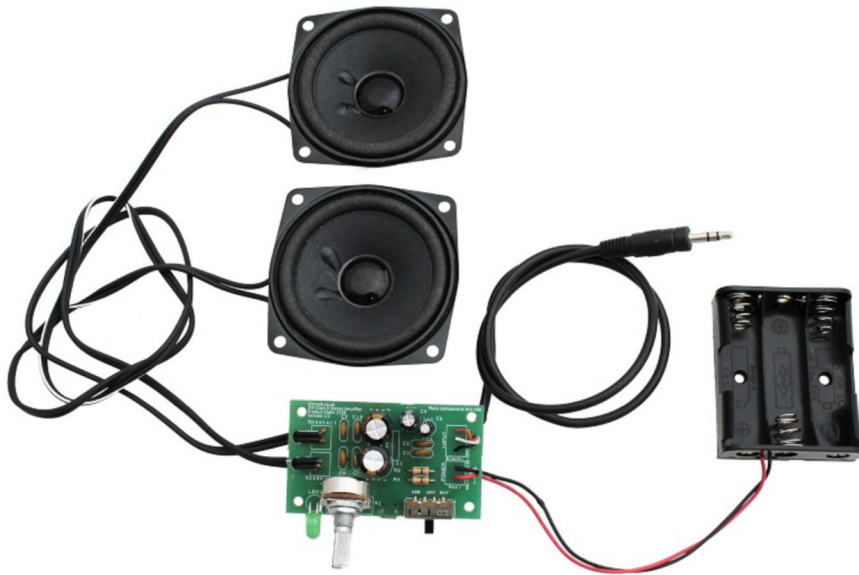

## Build Instructions

Before you start, take a look at the Printed Circuit Board (PCB). The components go in the side with the writing on and the solder goes on the side with the tracks and silver pads.

### 1 PLACE RESISTORS

Start with the three resistors:  
The text on the PCB shows where R2, R3 etc go.  
Ensure that you put the resistors in the right place.

PCB Ref	Value	Colour Bands
R2 & R4	0Ω	Black
R3	220Ω	Red, Red, Brown



### 2 SOLDER THE PCB MOUNT SWITCH

Solder the PCB Mount Right Angled On / Off Switch into the PCB where it is marked “USB OFF BAT”. The row of four pins that exit the back of the switch must be soldered but the other two pins don't need soldering. Make sure the switch is all the way in and flat to the board before soldering.

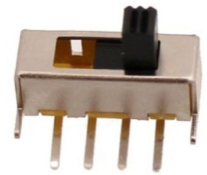

### 3 SOLDER THE CERAMIC DISC CAPACITORS

The text on the PCB shows where C1, C2 etc go.  
Ensure that you put the capacitors in the right place.

PCB Ref	Value	Marking
C1 & C2	100nF	104
C7, C8, C9 & C10	10nF	103



### 4 SOLDER THE LED

The LED can be have the legs bent if it needs to go out of the front of the case or can be put on flying leads. Solder the LED into the PCB where it is labelled LED1. When putting it into the board, **make sure that the flat edge on the LED matches the outline on the PCB.**



# 3W Stereo Amplifier Essentials

www.kitronik.co.uk/2158



5

## SOLDER THE ELECTROLYTIC CAPACITORS

Now solder the four electrolytic capacitors. The capacitors have text printed on the side that indicates their value. The  $1\mu\text{F}$  capacitor should be soldered into C6 on the PCB and the  $220\mu\text{F}$  capacitor should be soldered into C4. The two large  $1000\mu\text{F}$  capacitors (C3 & C5) go into the two large capacitor outlines marked on the PCB. Make sure that the capacitors are the correct way around. **The capacitors have a '-' sign marked on them, which should match the same sign on the PCB.**

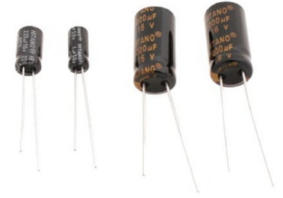

6

## SOLDER THE POTENTIOMETER

Solder the potentiometer into the PCB where it is labelled R1. Make sure that the volume knob is facing away from the PCB.



7

## CONNECT THE SPEAKERS

The kit is supplied with a metre of twin cable. This cable will be used to connect the two speakers. You will need to cut this to the required length to connect each speaker in your enclosure design.

Take each piece of twin cable and strip & tin the ends of the wire. Connect one end of each wire to the two terminals on each speaker (as shown). You will see that the speakers have '+' and '-' indicators. Take the cable connected to one speaker and connect it to the pads labeled 'Speaker 1' on the PCB. The connections on the pads are also labeled with a '+' and '-'. The '+' on the PCB needs to go to the '+' on the speaker and '-' to '-'.



Repeat with the second speaker, this time connecting to the pads labelled 'Speaker 2'.

8

## CONNECT THE BATTERY PACK

The kit is supplied with a 3x AA battery pack on leads that can be used to power the kit. First thread both wires through the stress relief hole then solder the red wire into the PCB where it is marked 'Red +' and the black wire into the PCB where it is marked 'Black -'.



9

## CONNECT THE AUDIO CABLE

The stereo Jack lead should be connected to the 'INPUT' terminal. First feed the wires through the strain relief hole. The black wire should be connected to the terminal labelled 'GND'. The other two wires can go to either of the two remaining inputs.

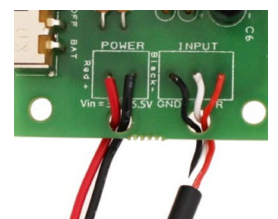



## Checking Your Amplifier PCB

Carefully check the following before you connect the power:

**Audio equipment may become damaged if connected to an incorrectly built amplifier.**

### Check the bottom of the board to ensure that:

- All holes (except the 4 large (3mm) holes in the corners) are filled with the lead of a component.
- All these leads are soldered.
- Pins next to each other are not soldered together.

### Check the top of the board to ensure that:

- The battery cage connects to the board where it is labelled 'POWER' and the red wire is next to the red text.
- The '-' on the capacitors match the same marks on the PCB.
- The capacitors C1 & C2 have 104 printed on them.
- The colour bands on R3 are red, red, brown.
- The 'Gnd' labelled terminal on the 'INPUT' connection has the black wire connected to it.
- The flat edge on the LED matches the outline on the PCB.
- The values on the electrolytic capacitors are correct.



## Fault finding flow chart

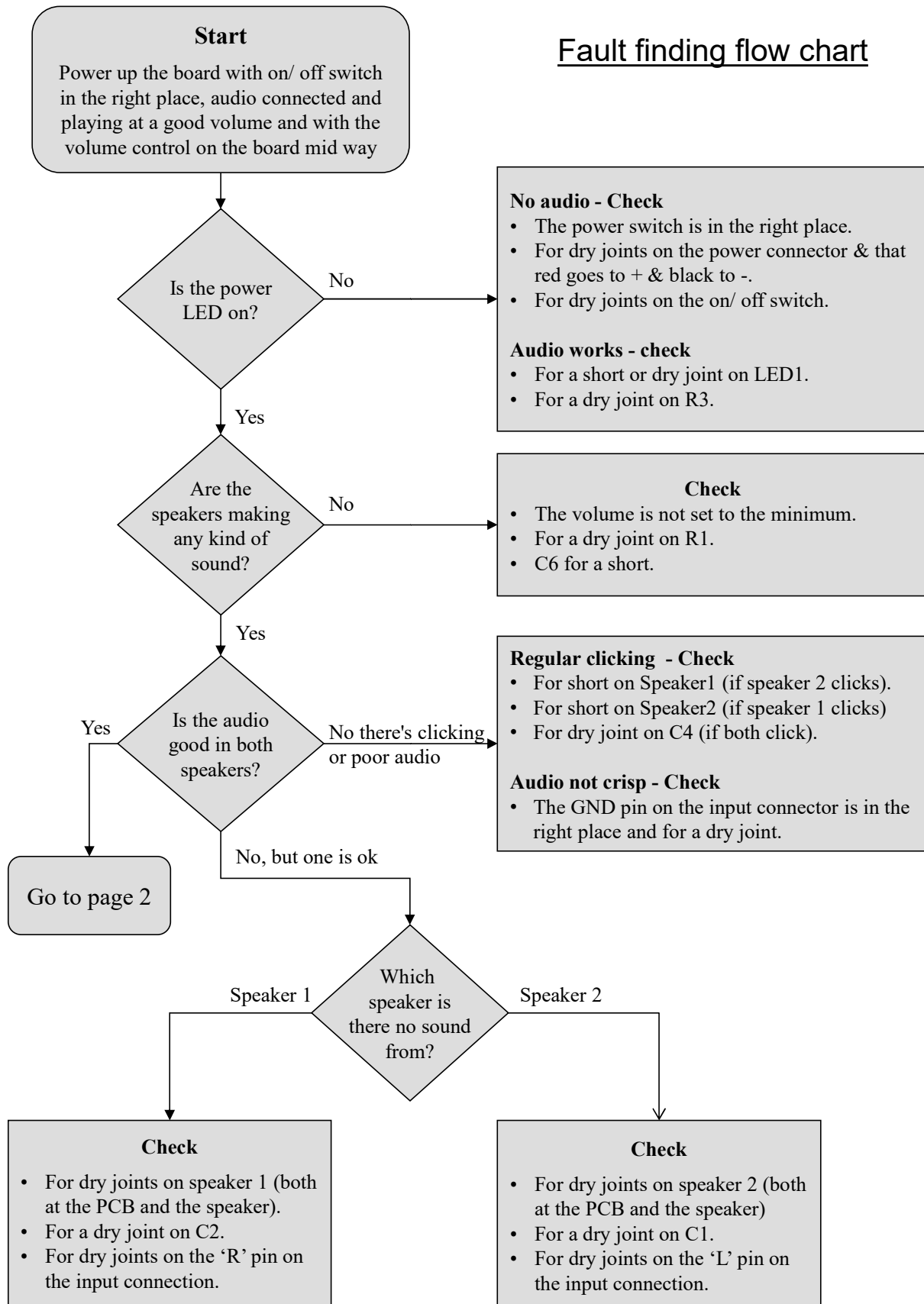

## Fault finding flow chart continued

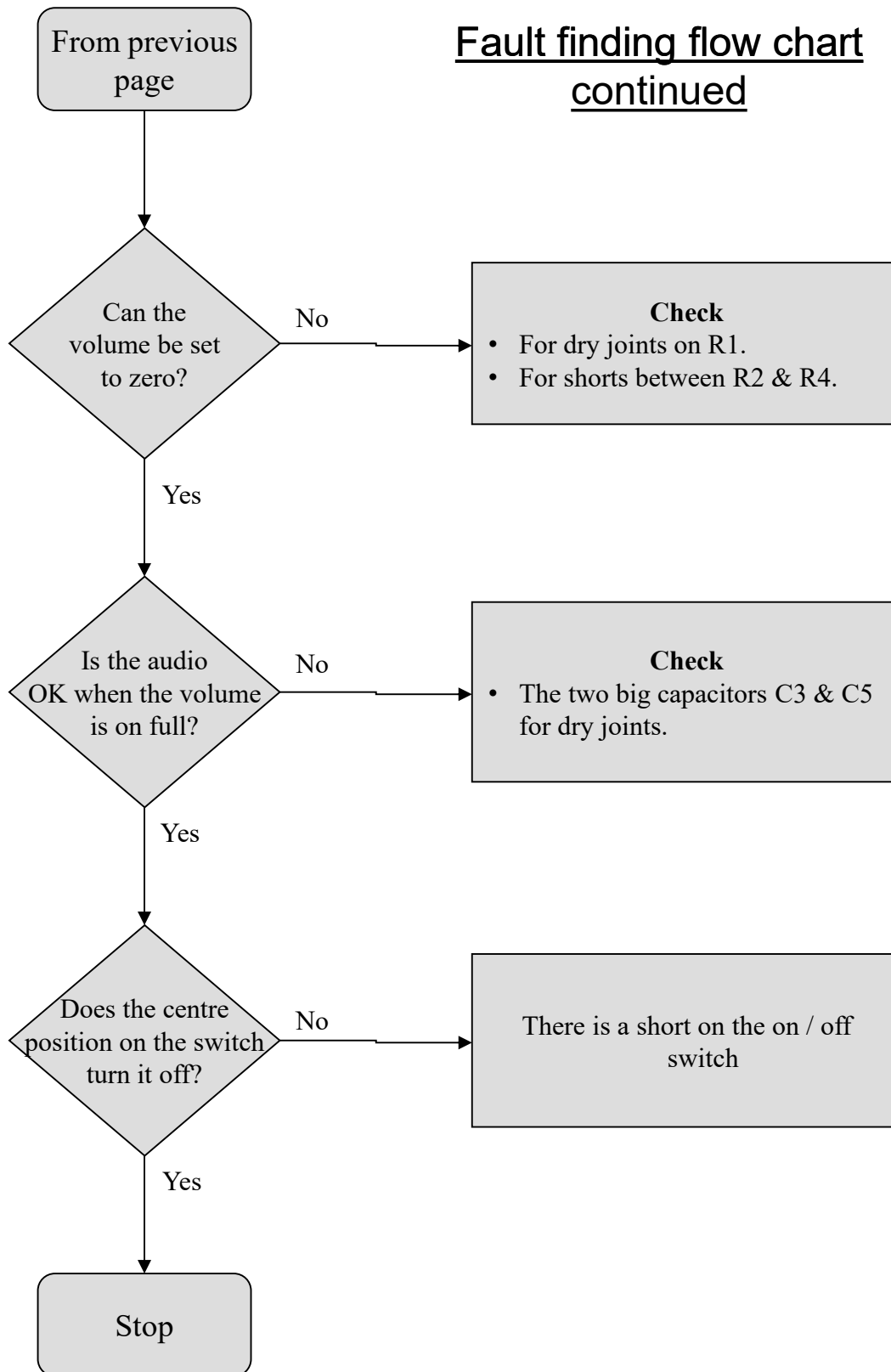

## Designing the Enclosure

When you design the enclosure, you will need to consider:

- The size of the PCB (right).
- How to mount the speaker (below).
- How to allow the audio cable out of the box.
- Are you making the amplifier for a particular MP3 player, if so should the player go in the box?

These technical drawings of the amplifier PCB and speaker should help you to plan this.

All dimensions in mm

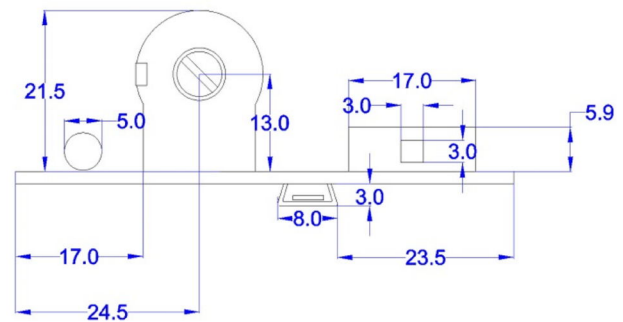
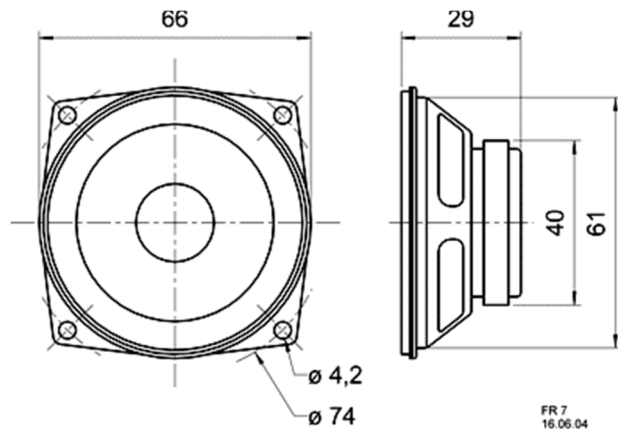
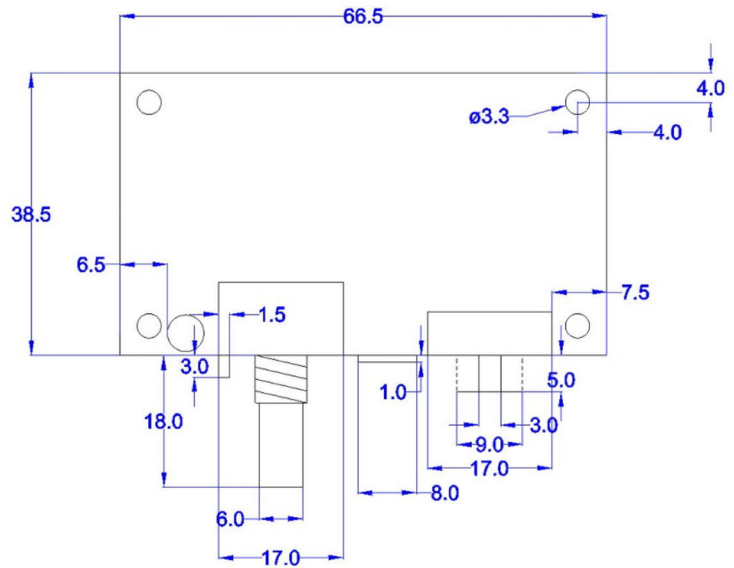

	<p><b>Mounting the PCB to the enclosure</b></p> <p>The drawing to the left shows how a hex spacer can be used with two bolts to fix the PCB to the enclosure.</p> <p><i>Your PCB has four mounting holes designed to take M3 bolts.</i></p>
--	---



## How the Amplifier Works

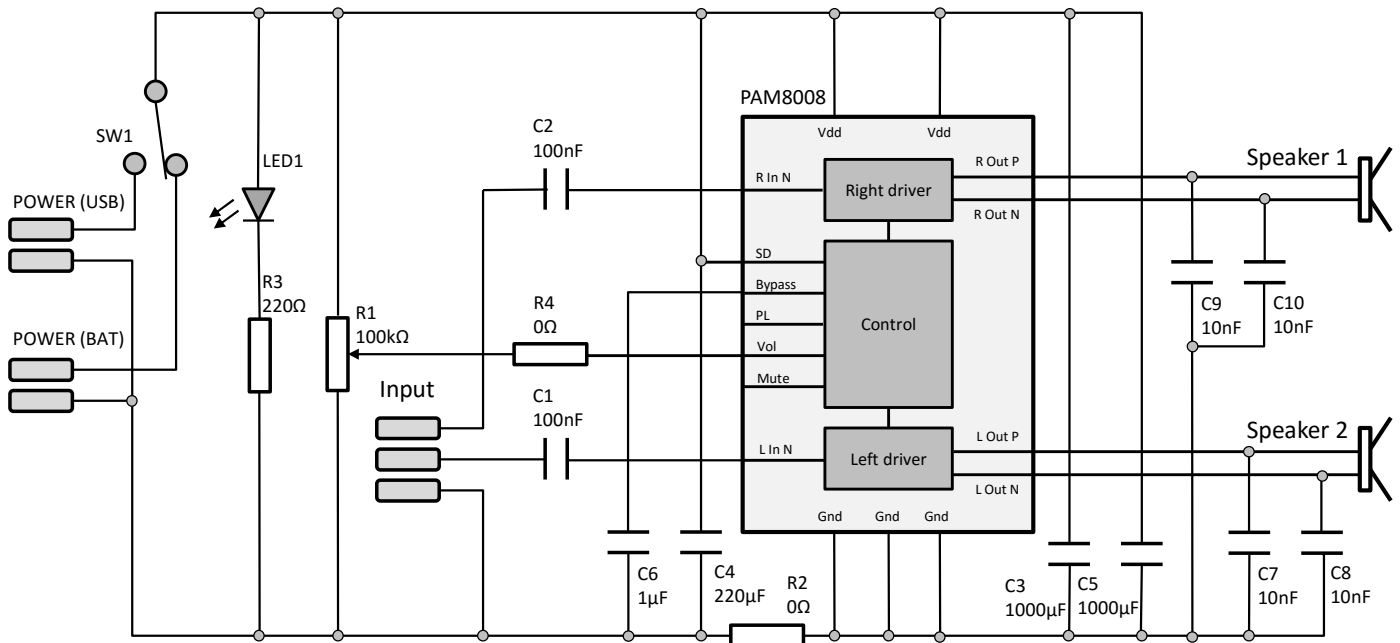

The 3W amplifier uses a PAM8008 amplifier IC, this delivers 3W across the two channels and contains a number of features to make the circuit simple and compact. The device automatically reduces the volume to prevent distortion, has an internal digital volume control and offers over temperature and short circuit protection.

The audio connected to the input connector goes through the de-coupling capacitors C1 & C2 and into the amplifier IC where it is amplified. The output signal is at a higher voltage and current than the input signal so that it can drive the 4Ω speakers. The driver within the amplifier IC is able to change the voltage on both sides of the speaker which gives twice the voltage range, compared to any amplifiers where only one side of the speaker is driven. This removes the need for a large capacitor on the output and improves the volume of the amplifier. There are also two 10nF capacitors on each channel (C7 to C10) placed between the speaker and ground, these act as a filter allowing the maximum volume to be reached.

The capacitors C3 to C5 are all placed across the power supply and are present to keep the voltage as stable as possible. The bypass pin is used control the audio during power up in order to stop it clicking and popping as the circuit starts up. It is also controls how the amplifier resumes after it has gone in to shut down, the value of C6 controls how long the output is bypassed for.

The volume of the amplifier is controlled by a voltage on the volume pin. This arrangement allows for a single volume potentiometer (R1) to control the volume on both channels. There is a power LED present (LED1) and the resistor R3 has been selected to limit the current in to the LED so that it is illuminated at a good brightness. Finally the circuit can be powered of batteries (3x AA) or from a USB supply. These are connected to a switch (SW1) that also has a centre off position. The switch is able to connect battery power, nothing (powered off) or USB power to the rest of the circuit.

R4 and R2 are just to jump over tracks on the PCB, this allows the circuit to fit onto a single sided PCB to keep down cost.



## Online Information

Two sets of information can be downloaded from the product page where the kit can also be reordered from. The 'Essential Information' contains all of the information that you need to get started with the kit and the 'Teaching Resources' contains more information on soldering, components used in the kit, educational schemes of work and so on and also includes the essentials. Download from:

[www.kitronik.co.uk/2158](http://www.kitronik.co.uk/2158)



This kit is designed and manufactured in the UK by Kitronik

---

**Telephone:** +44 (0) 845 8380781

**Sales email:** [sales@kitronik.co.uk](mailto:sales@kitronik.co.uk)

**Tech support email:** [support@kitronik.co.uk](mailto:support@kitronik.co.uk)

**Web:** [www.kitronik.co.uk](http://www.kitronik.co.uk)



[www.kitronik.co.uk/twitter](http://www.kitronik.co.uk/twitter)



[www.kitronik.co.uk/facebook](http://www.kitronik.co.uk/facebook)



[www.kitronik.co.uk/youtube](http://www.kitronik.co.uk/youtube)



[www.kitronik.co.uk/google](http://www.kitronik.co.uk/google)

---

Every effort has been made to ensure that these notes are correct, however Kitronik accept no responsibility for issues arising from errors / omissions in the notes.

© Kitronik Ltd - Any unauthorised copying / duplication of this booklet or part thereof for purposes except for use with Kitronik project kits is not allowed without Kitronik's prior consent.

