

THIS DRAWING IS UNPUBLISHED. RELEASED FOR PUBLICATION  
 © COPYRIGHT - By - ALL RIGHTS RESERVED.

LOC		DIST		REVISIONS			
P	LTR	DESCRIPTION		DATE	DWN	APVD	
G	14	C1		REVISED PER ECO-13-000091	04JAN13	KH	DR

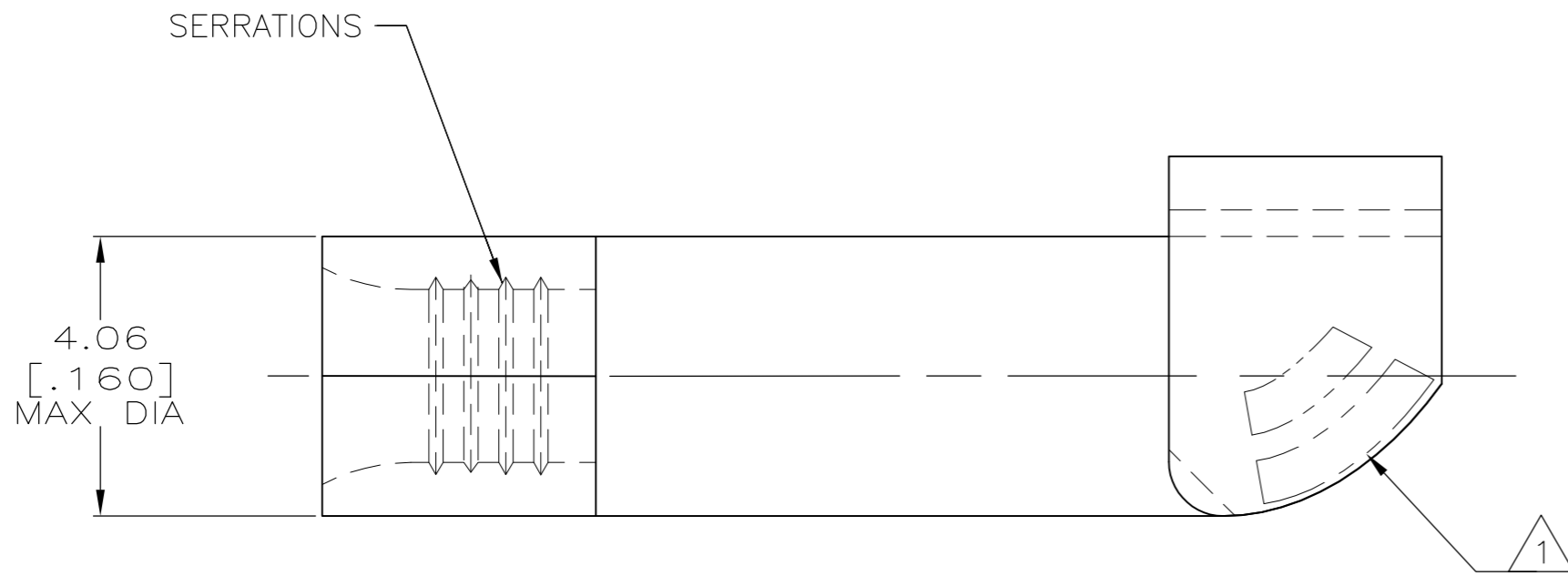

<b>AMP</b> WIRE RANGE	<b>UL</b> E13288 RECOGNIZED
16-14 AWG STRANDED	16-14 AWG STRANDED
<b>SP</b> LR7189 Certified	MILITARY P/N AND CLASS
NOT CERTIFIED	NOT APPLICABLE

△ 1 STAMP AMP 16-14\* APPROX AS SHOWN

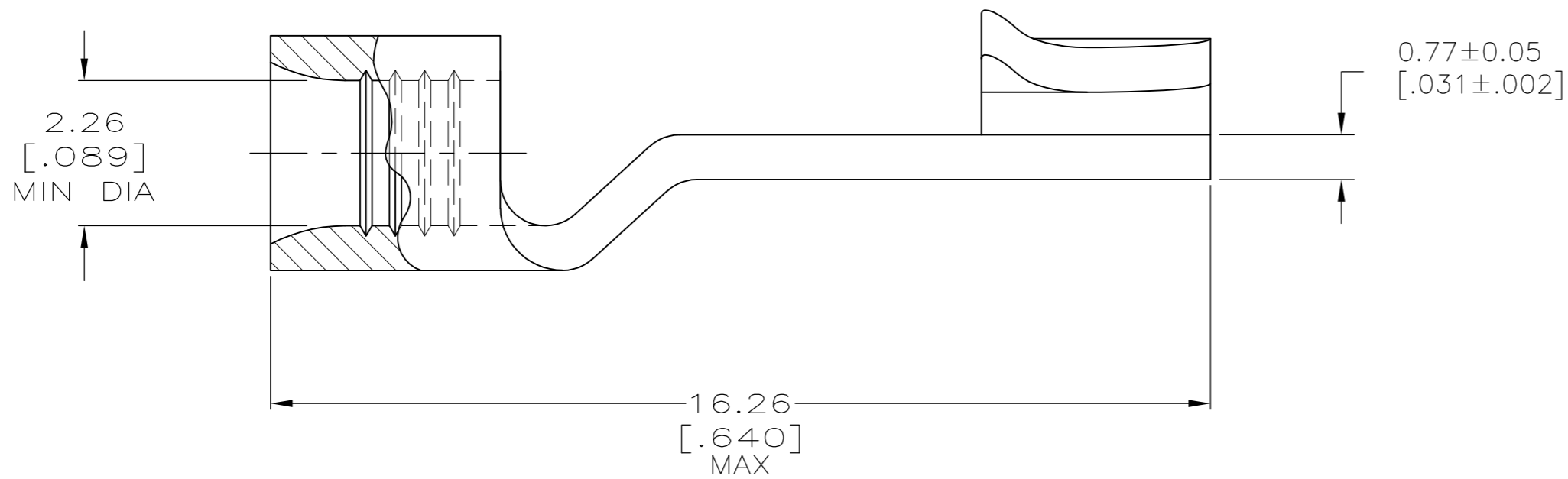

### AMP INCORPORATED CUSTOMER SERVICE SYSTEMS

MAX RECOMMENDED OPERATING  
TEMPERATURE:  
170° C MAX

FOR ADDITIONAL  
PRODUCT INFORMATION OR  
COPIES OF DRAWINGS  
AND TECHNICAL DOCUMENTS

PRODUCT INFORMATION CENTER  
1-800-522-6752

VOLTAGE RATING:  
NOT APPLICABLE

FOR APPLICATION  
TOOLING INFORMATION

TOOLING ASSISTANCE CENTER  
1-800-722-1111

WIRE CROSS SECTIONAL AREA RANGE:  
1.04-2.62mm<sup>2</sup> [2,050-5,180] CIR MILS  
STRANDED

FOR ORDER ENTRY

1-800-526-5142

THIS DRAWING IS A CONTROLLED DOCUMENT FOR  
AMP INCORPORATED. IT IS SUBJECT TO CHANGE  
AND THE CONTROLLING ENGINEERING ORGANIZATION  
SHOULD BE CONTACTED FOR THE LATEST REVISION.

OBSOLETE	5000	ON TAPE, REEL	2-31938-1
		LOOSE PIECE	31938
QTY		PACKAGE TYPE	PART NO

THIS DRAWING IS A CONTROLLED DOCUMENT.		DWN DK SCHRUM 05JUL94	<b>TE</b> TE Connectivity	
DIMENSIONS: mm [INCHES]		CHK DA PATTERSON 08AUG94		
TOLERANCES UNLESS OTHERWISE SPECIFIED:		APVD CH KULYNYCH 08AUG94	NAME TERMINAL, KNIFE DISCONNECT, BUDGET	
0 PLC ± - 1 PLC ± - 2 PLC ± - 3 PLC ± - 4 PLC ± - ANGLES ± -		PRODUCT SPEC -	SIZE A2	
MATERIAL COPPER PER ASTM B-152 ANNEALED		FINISH TIN PLATE 0.00254[0.00100] MIN THK PER MIL-I-10727	APPLICATION SPEC -	CAGE CODE 00779
		WEIGHT -	DRAWING NO C-31938	RESTRICTED TO -
		CUSTOMER DRAWING	SCALE 10:1	SHEET 1 OF 1
			REV C1	